

986D SERIES 52mm DIA (EPICYCLIC) METAL GEARBOX

RE-800 MOTOR



RATIOS NOW AVAILABLE AS EX-STOCK ITEMS.

986D41	(6v - 12v)	RATIO 4:1
986D431	(6v - 12v)	RATIO 43:1
986D1001	(6v - 12v)	RATIO 100:1
986D4881	(6v - 12v)	RATIO 488:1

Designed for heavy-duty industrial and model applications this robust unit boasts a powerful high quality motor with scintered bronze bearings. The metal gearbox incorporates ballrace bearings, enabling the high torque transfer from the motor to be transmitted through the gearbox. The extended rear motor shaft can facilitate encoder installation.

MOTOR DATA. (RE-800)

MODEL	VOLTAGE		NO LOAD		AT MAXIMUM EFFICIENCY					STALL TORQUE		
	OPERATING RANGE	NOMINAL	SPEED	CURRENT	SPEED	CURRENT	TORQUE		OUTPUT	EFF		
			R.P.M.	A	R.P.M.	A	oz-in	g-cm	W	%	oz-in	g-cm
RE-800	6 - 12	12v Constant	5000	1.1	4340	4.6	12.07	869	38.73	70.2	87.0	6264

Stall Current RE-800 at 12v = 25.86A

REDUCTION TABLE. R.P.M. (NO LOAD)

SUPPLY VOLTAGE	6v	12v
986D41	625	1250
986D431	58	116
986D1001	25	50
986D4881	5	10

WEIGHT	
986D41	976g
986D431	1356g
986D1001	1319g
986D4881	1483g

Note: Motor speeds may vary by (+) or (-) 12.5%

GEARED MOTOR TORQUE RATINGS AT MAX. EFFICIENCY.

	At 12v (g.cm)
4:1	2781
43:1	22420
100:1	52140
488:1	100000

986D SERIES	
No Load Backlash	Max 3 deg.
Max Radial Load (10mm from flange)	20000gf.
Shaft Axial Load	10000gf.

NOTE: To establish Torque Rating in Nm, divide g.cm by 10,197.0

IMPORTANT NOTICE

At very low ratios the torque produced by this geared motor combination may exceed the maximum permissible torque of the gearbox. In this situation the unit must not be allowed to stall as this may damage the gears.

IMPORTANT NOTICE

Due to the wide range of applications for this product it is the users responsibility to establish the products suitability for their individual purpose(s).

986D SERIES 52mm DIA (EPICYCLIC) METAL GEARBOX

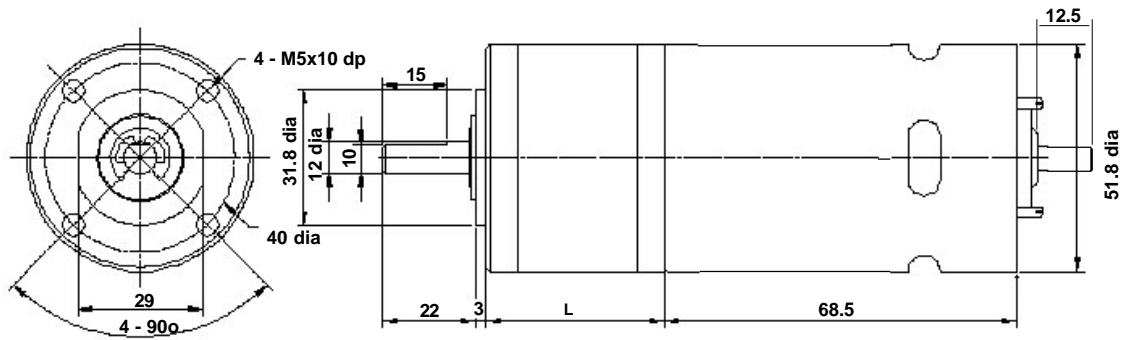

RATIO	L
4:1	53.5
43:1	84.0
100:1	84.0
488:1	99.5

NOTE: all diameters in mm

ADVANTAGES OF PLANETARY GEARBOXES.	
EFFICIENCY:	Efficiencies of planetary gearboxes can be above 90% while some other types of transmission can be 50% or less. This allows the use of smaller motors.
SIZE:	Planetary gearboxes can be half the size of conventional boxes.
WEIGHT:	Weight savings can be as high as 60%, allowing smaller, lighter support structures.
MAINTENANCE:	Other than routine oil changes, no maintenance is required, eliminating the need to hold spares.
REVERSIBLE:	Planetary gears can be equally efficient in either direction. This is an advantage for use in running machinery in both clockwise and anti-clockwise directions.
COAXIAL:	The coaxial configuration of input and output shafts allows planetary gears to be installed in line with a motor and a machine.

Subject to minimum order quantities of 250 units, the following ratios are also available with a six week lead-time. The physical dimensions of these other gearboxes may vary from the data as illustrated above. Details of individual gearboxes are available upon request.

GEARBOX 3:1 WITH 800 MOTOR
 GEARBOX 12:1 WITH 800 MOTOR
 GEARBOX 15:1 WITH 800 MOTOR
 GEARBOX 19:1 WITH 800 MOTOR

GEARBOX 53:1 WITH 800 MOTOR
 GEARBOX 66:1 WITH 800 MOTOR
 GEARBOX 81:1 WITH 800 MOTOR
 GEARBOX 113:1 WITH 800 MOTOR

GEARBOX 150:1 WITH 800 MOTOR
 GEARBOX 230:1 WITH 800 MOTOR
 GEARBOX 285:1 WITH 800 MOTOR
 GEARBOX 353:1 WITH 800 MOTOR

GEARBOX 546:1 WITH 800 MOTOR
 GEARBOX 676:1 WITH 800 MOTOR